

Differential Transformer System **Submerged Level Detector**

# SL-180B

ISO9001  
CERTIFIED  
JQA  
MANAGEMENT SYSTEM  
QUALITY SYSTEM  
JQA-0950

Reliable measurement of water level  
for water level monitoring and automatic control of pump

**For water purification plants and  
small water-supply systems**



- Accuracy of  $\pm 0.2\%$
- Differential transformer system for excellent lightning protection and high resistance to environmental factors
- Easy maintenance



**JFE Advantech Co., Ltd.**

# Submerged Level Detector SL-180B

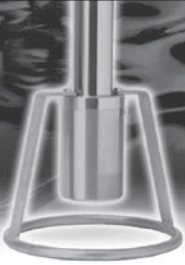

Please read the operation manual before using the product.

## Specifications

Measuring range	Range selectable from 0 - 0.1 m to 0 - 40 m	Lightning protection	10 kV (lightning protection circuits built in power supply and output sections)
Accuracy	±0.2% of span (±0.5% in the case of 0 - 0.8 m)	Material	Detector : Type 316 stainless steel Junction box : SMC resin
Temperature characteristic	±0.015% / °C of span (±0.05% / °C in the case of 0 - 0.8 m)		
Operating temperature range	Detector : -10 to 50 °C (no freezing allowed) Junction box : -5 to 60 °C (Guaranteed Indicator operating range : 0 to 50 °C)	Hollow cable	Outer diameter : 12 mm Jacket : heat-resistant vinyl sheath
Output signal	4 to 20mA DC (2-wire type) Allowable load resistance : 390 Ω (at power supply voltage 24V)	Lifting chain	Wire diameter : 3 mm Material : Type 316 stainless steel
Allowable overload	3 m when maximum measurement value is 0.8 m or less 12 m when maximum measurement value is more than 0.8 m and up to 3 m 45 m when maximum measurement value is more than 3 m and up to 40 m	Weight	Detector : approx. 2.5 kg Junction box : approx. 0.9 kg
		Power source	DC16.2 to 30V

## Components

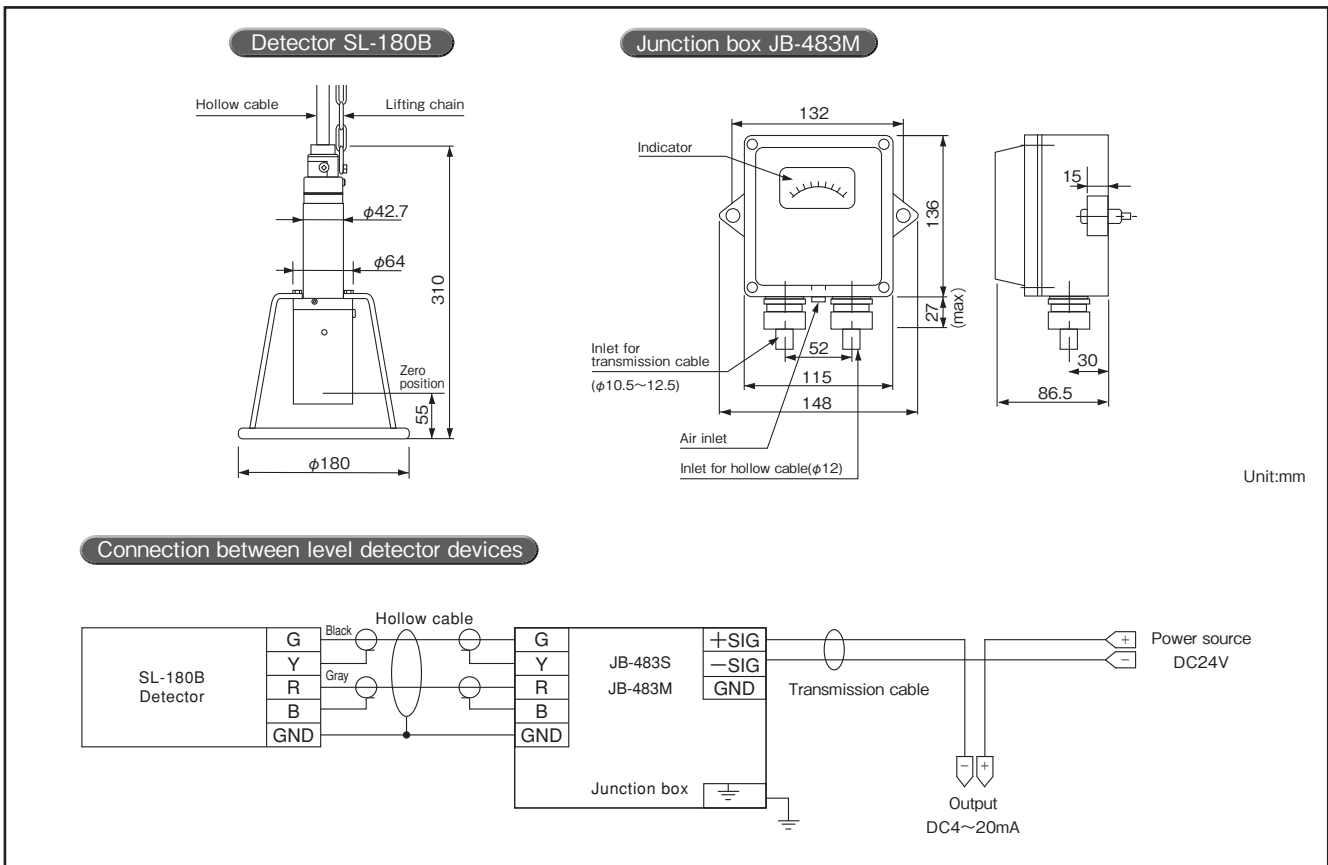

\*Specifications in this catalog are subject to change without prior notice due to product improvement.

**JFE Advantech Co., Ltd.**  
URL : <https://www.jfe-advantech.co.jp/eng/>

**Tokyo Office (Overseas Sales Department)**  
JFE Kuramae Bldg. 2F, 2-17-4 Kuramae, Taito-ku, Tokyo  
111-0051, Japan  
Tel.+81-3-5825-5577 Fax.+81-3-5825-5591

**Water Environment Division**  
3-48, Takahata cho, Nishinomiya, Hyogo,  
663-8202, Japan  
Tel.+81-798-66-1502 Fax.+81-798-65-7025